

# HUMMER H2

## Reclining Kit for rear seat

## Instruction Manual

Thank you for purchasing this product. Please read this manual carefully before installing and using this product. Please keep this manual for ready reference.

### **Precautions: Read this before using this product.**

- Change the seat back angle by raising the adjustment lever to its upper limit.
- Do NOT raise the adjustment lever while leaning against the seat back. This is highly dangerous.
- Do NOT take a seat with the adjustment lever raised.
- Do NOT put your hand close to the brackets. You will hurt your hand if it is caught in the brackets.
- When mounting a child safety seat etc., make sure to set the seat back in the angle specified in the instruction manual of the child safety seat.
- STOP the reclining operation when you find that the operation cannot be made smoothly.
- To prevent accidents, periodically check if the screws are loose, the parts are damaged, etc.
- When using this product for the first time or driving a long period of time with several persons seated, check each part of the product for every 100 km driving.
- This product can be installed only to the factory supplied 60/40-split rear seat of HUMMER 2004 year or later model. Do NOT install this to the other models or non-factory supplied seats.
- The reclining operation cannot be made with the spare wheel in the luggage room.
- The left rear seat cannot be reclined with the tire jack mounted behind it.

### **For maintenance**

- Apply grease to the moving parts periodically. (Be sure to apply grease whenever you find that the operation cannot be made smoothly.)
- This product is made of galvanized steel. Clean this product when it becomes tarnished to prevent it from rusting. Do NOT clean this product with chemicals etc.

Manufacturer:

Fukshin-Industry Co. Sunrocky Div.

105-3 Ida, Kitasaki-cho, Obu-shi, Aichi-ken

Phone: 0562-46-8662

Fax: 0562-46-8663

<http://fukushin-ind.com>

---

## Installing the reclining kit

---

Read the following carefully before installing the reclining kit.

### Required tools

- Socket wrench 13 mm, 18 mm (an extension bar is also needed.)
- Spanner 13 mm, 18 mm
- Torque wrench (4.5 kgf max.)
- Others (if required): screwdriver, pliers, file, electric drill, etc.

### Notes before installation

Be sure to follow the notes below. If you do not, it may cause a serious accident or injury.

- Do the gloves while you install this product.
- Install the reclining kit in a flat and safe place with the engine stopped.
- The work must be performed by two or more adults.
- Install the reclining kit with the rear seat removed from the vehicle.
- Fasten the bolts in the following tightening torque securely:  
M10 – 3.0 kgf, M12 – 4.5 kgf

### Outline of the installation

The reclining kit is pre-assembled at the factory. The goal is simply to exchange the factory hinge assemblies with the reclining kit. Use the factory-supplied bolts and nuts.

When removing the factory brackets, keep in mind how they had been attached. Install the reclining kit in the same manner as the factory brackets had been attached.

### Completion drawing

This kit includes three hinge assemblies. Install the two with the levers to the left and right of the seat. The lever must be outside (on the door side). Install the one without the lever to the middle of the larger rear seat.

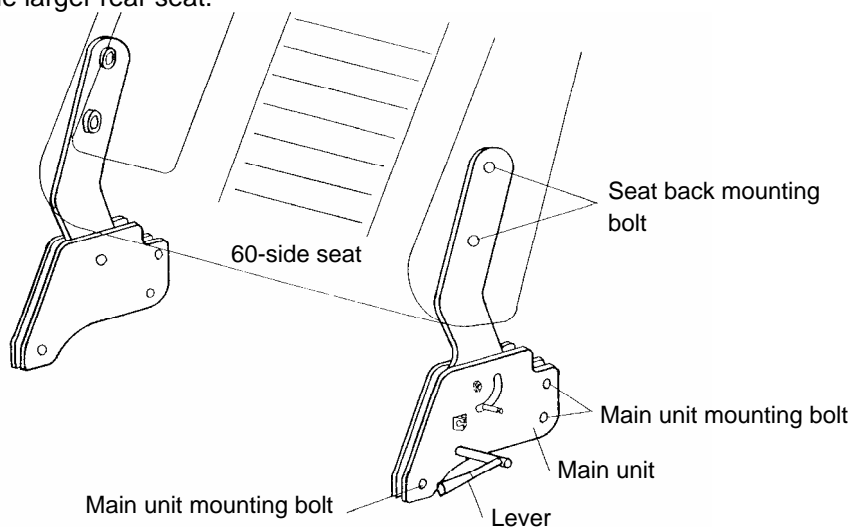

## Installation procedure

1. Raise the seat, and then remove the three plastic covers (black) on both sides and the middle side by prying them with the flat-blade screwdriver etc.

The nuts (silver, 4 pieces) appear where the covers are removed.

2. Remove the nuts with the 18 mm socket wrench.

\* The left and right seat frames are combined at the middle position. It is recommended to remove the nut beforehand.

3. Remove the connector for the seat heater.

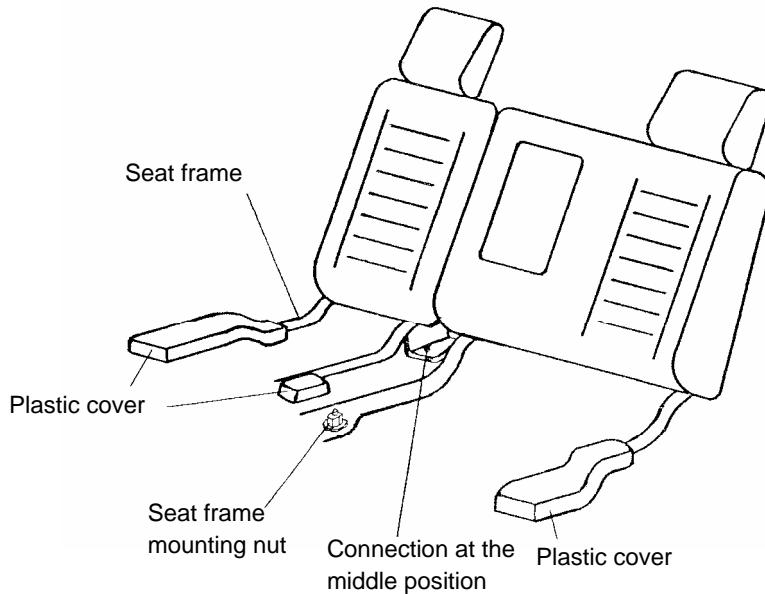

4. Fold the seat back forward, and then remove the carpet board.
5. Remove the four nuts fixing the seat frames.

This enables you to remove the seat and seat back with the frames.

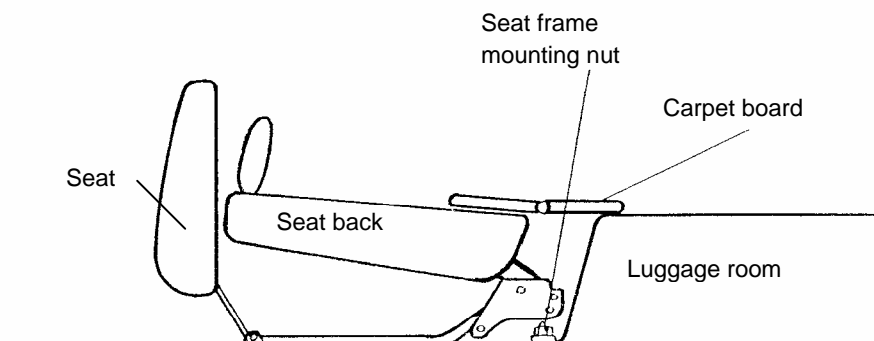

6. Remove the left and right seats, and then take them outside the vehicle.
7. Remove the wire attached to the hinge.
  - \* Both the end and the holder portions of the wire are simply inserted. Remove the wire by pulling it using the pliers etc. with no tension applied.

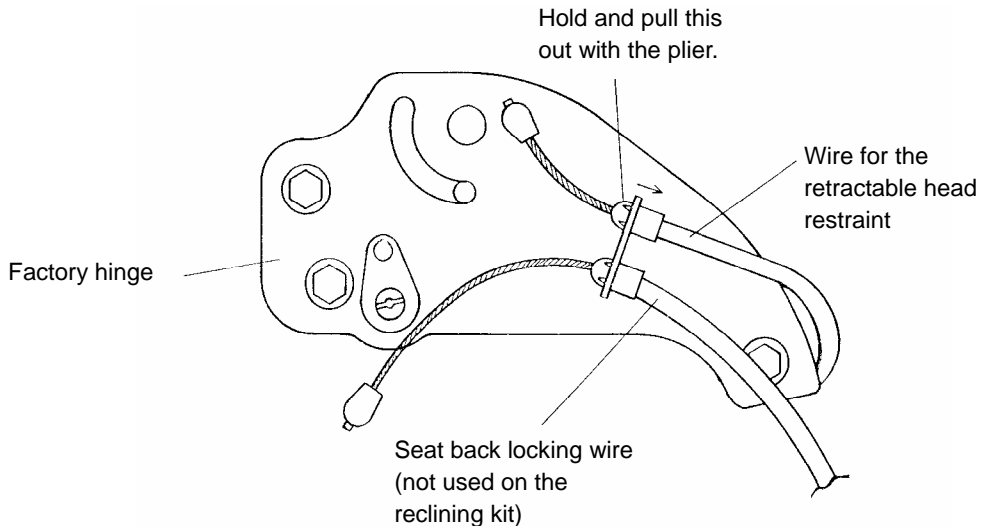

8. Flip up the leather cloth of the seat back. The cloth is fixed with the black plastic parts.

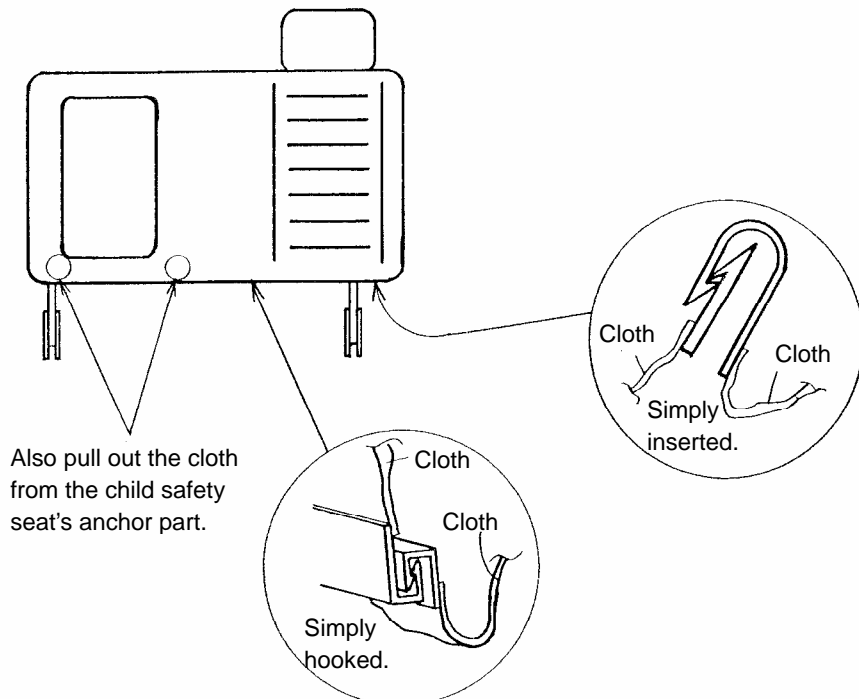

9. Remove the main part of the genuine hinge by removing the bolts (3 pieces) with the 13 mm socket wrench etc.

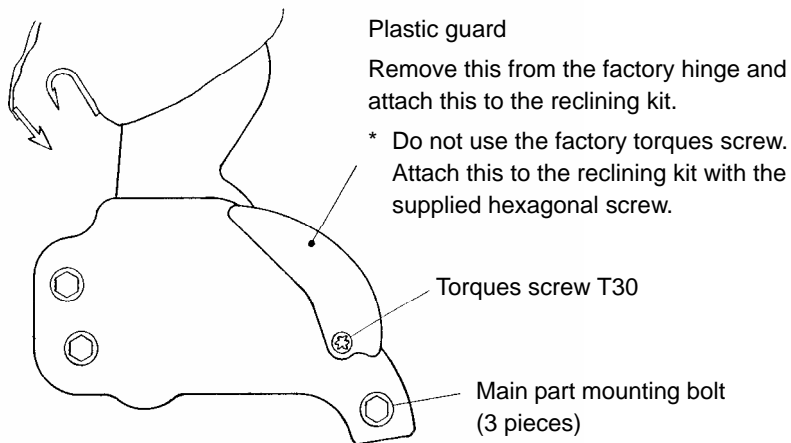

10. Remove the bolts from the left and right of the seat back, and then remove the factory brackets.
11. Attach the hinge brackets of the reclining kit at the same positions in the same manner as the factory brackets had been attached.
- \* Use all the genuine bolts and nuts for attaching the reclining kit. The brackets of the reclining kit are almost in the same shape as the factory-supplied ones.
  - \* It is recommended to attach the reclining brackets one by one (attach each bracket just after the corresponding factory bracket is removed) to prevent mistakes.
  - \* Attach the wire for the retractable head restraint in the same manner as it had been attached to the genuine hinge.
  - \* The seat back locking wire will not be used. Fix it to the near wire etc. with the supplied TY-RAP cable tie.
12. After attaching the brackets, cover the seat with the leather cloth.

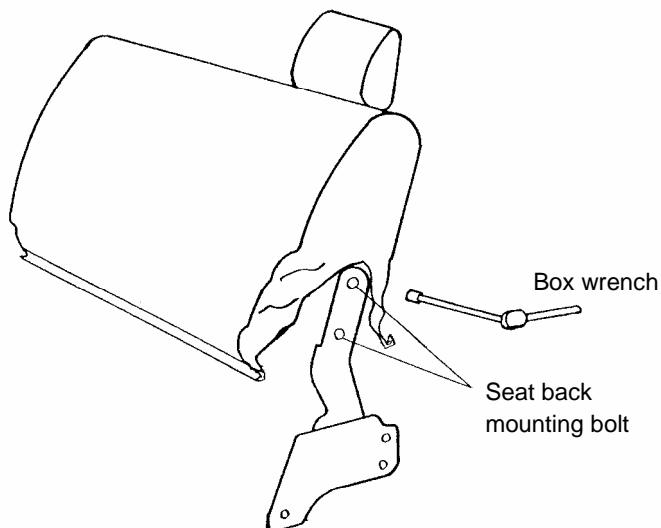

13. Mount the seat on the vehicle.
14. Attach the seat in the reverse order of step 1 to 6.  
The installation has completed.

**Note**

- Do NOT make the reclining operation when you find that the operation cannot be made smoothly.
- There is a case that the angles of the left and right seats are somewhat different because of the backlash of bolt holes used for fixing the reclining kit.